

QIC-36  
Revision C  
14 Sep 84



# DEVELOPMENT STANDARD

---

## 1/4-INCH CARTRIDGE TAPE DRIVE BASIC INTERFACE

Quarter-Inch  
Cartridge  
Drive Standards, Inc.

311 East Carrillo Street  
Santa Barbara, California 93101  
Telephone (805) 963-3853  
Fax (805) 962-1541

---

(See important notices on following page)

### **Important Notices**

This document is a development standard adopted by Quarter-Inch Cartridge Drive Standards, Inc. (QIC). This document may be revised several times during the development cycle. It is intended solely as a guide for companies interested in developing products which can be compatible with other products developed using this document. QIC makes no representation or warranty regarding this document, and any company using this document shall do so at its sole risk, including specifically the risks that a product developed will not be compatible with any other product or that any particular performance will not be achieved. QIC shall not be liable for any exemplary, incidental, proximate or consequential damages or expenses arising from the use of this document. This development standard defines only one approach to the product. Other approaches may be available in the industry.

This development standard is an authorized and approved publication of QIC. The underlying information and materials contained herein are the exclusive property of QIC but may be referred to and utilized by the general public for any legitimate purpose, particularly in the design and development of quarter-inch cartridge tape drive subsystems. This development standard may be copied in whole or in part *provided* that no revisions, alterations or changes of any kind are made to the materials contained herein. Only QIC has the right and authority to revise or change the material contained in this development standard, and any revisions by any party other than QIC are totally unauthorized and specifically prohibited.

Compliance with this development standard may require use of one or more features covered by proprietary rights (such as features which are the subject of a patent, patent application, copyright, mask work right or trade secret right). By publication of this development standard, no position is taken by QIC with respect to the validity or infringement of any patent or other proprietary right, whether owned by a Member or Associate of QIC, or otherwise. QIC hereby expressly disclaims any liability for infringement of intellectual property rights of others by virtue of the use of this development standard. QIC has not and does not investigate any notices or allegations of infringement prompted by publication of any QIC development standard, nor does QIC undertake a duty to advise users or potential users of QIC development standards of such notices or allegations. QIC hereby expressly advises all users or potential users of this development standard to investigate and analyze any potential infringement situation, seek the advice of intellectual property counsel, and, if indicated, obtain a license under any applicable intellectual property right or take the necessary steps to avoid infringement of any intellectual property right. QIC expressly disclaims any intent to promote infringement of any intellectual property right by virtue of the evolution, adoption, or publication of any QIC development standard.

(This page left intentionally blank)

## Table of Contents

- 1.0 Scope
- 2.0 Physical Description
  - 2.1 Interface Characteristics
  - 2.2 Signal Termination
  - 2.3 Signal Loading
  - 2.4 Interface Connector
- 3.0 Electrical Description
  - 3.1 Signal Levels
  - 3.2 Pin Assignments
  - 3.3 Signal Lines To the Tape Drive
  - 3.4 Signal Lines From the Tape Drive
- 4.0 Control Implementation and Timing
- 5.0 Write and Erase Channels
- 6.0 Read Channel

## 1.0 SCOPE

This document defines the QIC-36 Basic Streaming Tape Interface. The primary objective of this interface is provide a low cost, high performance standard interface for attachment of Basic Streaming Tape Drives to controllers. These drives are designed to operate in streaming manner and record data at 10,000 fpi.

The Basic Streaming Tape Drive contains the mainframe, magnetic recording head assembly, capstan drive motor, tape hole sensors, 'cartridge in place' and 'safe' sensing switches, Read/Write electronics contains all PLL circuitry and is responsible for data encoding/decoding, tape formatting, and tape position control.

## 2.0 PHYSICAL DESCRIPTION

### 2.1 Interface Characteristics

There are 22 signal lines used at the Basic Tape Drive interface. Fifteen lines are used for signals that come from the Controller and seven lines are used for signals that originate at the Basic Tape Drive. Three lines are reserved and not used.

The signals are sent on lines of a 50-conductor cable which must not exceed 3 meters in length.

### 2.2 Signal Termination

The standard termination shall be 220 ohms to 5 VDC and 330 ohms to GND. Resistance tolerance shall be  $\pm 5\%$ . All signal lines to the controller shall be terminated at the controller, all signal lines to the drive shall be terminated at the drive.

### 2.3 Signal Loading

Signals transmitted by the drive are capable of driving 2 TTL loads plus terminator. Signal loading by the drive shall not exceed 2 TTL loads plus terminator.

### 2.4 Interface Connector

The signal connector on the drive is a 50-pin edge connector (Figure 1). Mating connector 3M type 3415-0001 or equivalent may be used.

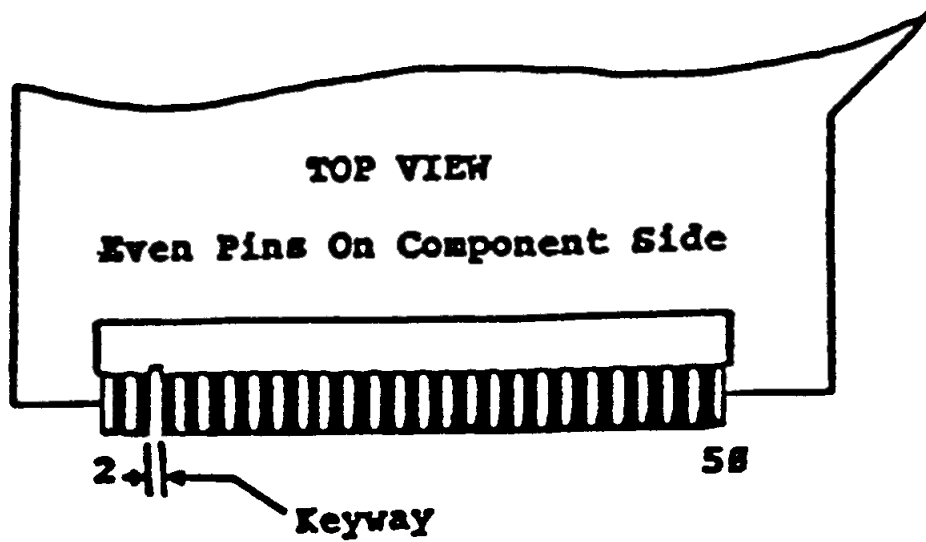

**INTERFACE CONNECTOR**

**FIGURE 1**

3.0 ELECTRICAL DESCRIPTION

3.1 Signal Levels

All voltage measurements are at the drive connector with terminators installed.

Standard TTL levels are used on signal lines to the controller as follows:

FALSE, logic 0 (high) = 2.4 to 5.25 VDC  
 TRUE, logic 1 (low) = 0.0 to 0.55 VDC

Standard TTL levels are required on signal lines to the drive as follows:

FALSE, logic 0 (high) = 2.0 to 5.25 VDC  
 TRUE, logic 1 (low) = 0.0 to 0.80 VDC

### 3.0 ELECTRICAL DESCRIPTION (cont'd)

#### 3.2 Pin Assignments

PIN #	NAME	TO	DESCRIPTION
02	GO-	D	Go Control for Capstan Servo
04	REV-	D	Direction Control for Capstan Servo
06	TR3-	D	Track Select Bit 3
08	TR2-	D	Track Select Bit 2
10	TR1-	D	Track Select Bit 1
12	TR0-	D	Track Select Bit 0
14	RST-	D	Reset
16	NUS		Not Used - unconnected signal line
18	NUS		Not Used - unconnected signal line
20	NUS		Not Used - unconnected signal line
22	DS0-	D	Drive 0 Select Control
24	HC-	D	Select operation with alternate type
26	RDP-	C	Read Pulse Output - one pulse per flux transition
28	UTH-	C	Upper Tape Position Code
30	LTH-	C	Lower Tape Position Code
32	SLD-	C	Response from Drive when selected
34	CIN-	C	Cartridge in Place
36	USF-	C	Unsafe - File Protect Plug is in "Unsafe" Position (Writing is enabled)
38	TCH-	C	Capstan Tachometer Pulses
40	WDA-	D	Write Data Signal
42	WDA+	D	Inverse Write Data Signal
44	THD-	D	Threshold - invokes a percentage qualifying amplitude for the read signal off tape
46	HSD-	D	High Speed - selects tape speed of 90
48	WEN-	D	Write Enable Control
50	EEN-	D	Erase Enable Control

C = Controller

D = Drive

All odd pins shall be signal returns and shall be connected to signal GND at the drive.

#### 3.3 Signal Lines To The Tape Drive

##### 3.3.1 Select (DS0-)

The assertion of DS0- will allow Basic Tape Drive operations to proceed. Erase and write current will be permitted under interface control and the output interface signals to the controller will be enabled. The drive selected (SLD-) signal will be generated in the basic drive and sent to the controller.

### 3.3.2 Reset (RST-)

Upon receiving a 13 microsecond or longer pulse on the RST- input signal line, the drive performs a maximum 10 second initialization routine and a recalibration of the head assembly to the reference position.

### 3.3.3 Go (GO-)

Assertion of GO- causes a start tape motion sequence in the direction specified by the state of REV-.

### 3.3.4 Reverse (REV-)

Assertion of REV- will cause tape motion in the reverse direction if GO- is asserted. De-assertion of REV- will cause tape motion in the forward direction if or when GO- is asserted.

### 3.3.5 Threshold (THD-)

Assertion of THD- invokes a percentage qualifying amplitude for the read signal. This is useful for eliminating marginal tape recording areas.

### 3.3.6 Track Select Bits (TR0-, TR1-, TR2- AND TR3-)

The track select bits are encoded as shown in the table below. The track select bits must remain in any given state for at least 500 msec to prevent erroneous track selection.

TR3-	TR2-	TR1-	TR0-	
0	0	0	0	Track 0
0	0	0	1	Track 1
0	0	1	0	Track 2
0	0	1	1	Track 3
0	1	0	0	Track 4
0	1	0	1	Track 5
0	1	1	0	Track 6
0	1	1	1	Track 7
1	0	0	0	Track 8
-	-	-	-	
1	1	0	X	Offtrack correction below track center
1	1	1	X	Offtrack correction above track center

The offtrack correction is performed relative to the center of the currently selected track. During offtrack correction, track select bit TR0- must remain in the appropriate state for the selected track since it is used to select the proper channel on the read/write head (i.e., logic 0 for tracks 0, 2, 4, 6 and 8 and logic 1 for tracks 1, 3, 5 and 7).



### 3.3.7 Write Data+ (WDA+) and Write Data- (WDA-)

WDA+ and WDA- are complementary signals sent to the basic interface at standard TTL voltage levels during the time WRITE ENABLE (WEN-) is asserted (Figure 4). The Basic Tape Drive read/write system is optimized to record GCR data at a nominal density of 10,000 flux transitions per inch (ftpi).

### 3.3.8 High Current (HC-)

Assertion of HC- enables operation with tape cartridges which comply with ANSC Project 671, X3B5/84-59, Third Draft Unrecorded Magnetic Tape Cartridge For Information Interchange, 0.250 inch (6.30 mm), 10000 ftpi (394 ftpmm), High Coercivity.

### 3.3.9 Erase Enable (EEN-)

EEN- will enable erase current to the full-tape-width erase head if select signal DS0- is asserted and track 0 is selected.

### 3.3.10 Write Enable (WEN-)

The WEN- input must be asserted for write data to be gated to the write head.

### 3.3.11 High Speed (HSD-)

HSD- is a signal provided to allow the 30 ips basic drive to move tape at 90 ips when performing tape motion operations (erase, rewind and retension) which do not require reading from or writing to tape.

## 3.4 Signal Lines From The Tape Drive

### 3.4.1 Read Data Pulses (RDP-)

Bit-serial Read data is present at the Drive interface. Since no read enable is required, Read Data Pulses (RDP-) will be present any time data passes under the Read Head and DS0- is asserted (Figure 4).

### 3.4.2 Upper Tape Hole (UTH-) and Lower Tape Hole (LTH-)

The UTH- and LTH- signals are present at the Drive interface if DS0- is asserted. BOT, Load Point, Early Warning and EOT tape hole information is encoded to produce an output code indicating specific positions on the tape.

#### 3.4.3 Drive Selected (SLD-)

SLD- is asserted as a response to DS0-, indicating the Drive has been selected.

#### 3.4.4 Cartridge In (CIN-)

CIN- is present at the Drive interface if DS0- is asserted. CIN- is asserted when a tape cartridge is fully inserted and actuates the cartridge-in switch. CIN- is deasserted when the tape cartridge is removed.

#### 3.4.5 Unsafe (USF-)

USF- is present at the drive interface if DS0- is asserted. USF- is asserted and Writing (Erasing) to tape is permitted, when the File Protect Plug on the Tape Cartridge is not in the safe position.

#### 3.4.6 Tachometer Pulses (TCH-)

TCH- is present at the interface if DS0- is asserted. The pulses inform the controller when tape is moving how far. The distance traveled by the tape between tachometer pulses shall be within the range of .1 to .2 inches.

## 4.0 CONTROL IMPLEMENTATION AND TIMING

4.1 Upon power up or assertion of Reset (RST-) the drive performs a three-second power up initialization and a recalibration of the stepper motor positioner to the reference position.

The signals SLD-, TRI-, TR2-, TR3-, REV-, GO-, CIN-, UTH-, LTH- are monitored at a maximum 10 msec interval. When detected, control functions are performed in the following priority:

1. Track position
2. Tape hole response
3. Motion control

Signals may not be monitored while the drive is performing any of the following:

1. Track selection sequence (3 sec/track maximum)
2. Tape start sequence (300 msec maximum)
3. Tape stop sequence (300 msec maximum)

Drive control signals are not responded to unless DS0- is asserted. De-assertion of DS0- causes a tape stop sequence to occur. A change in state of the track select lines causes a track selection sequence to be performed to locate a recording head on the required track. Typical tape motion timing is shown in Figure 2. Assertion of GO- causes a tape start sequence in the direction specified by the state of REV-.

It is permissible to change the state of TRI-, TR2- or TR3- and REV- while GO- is asserted. Changing the state of TRI-, TR2- or TR3- while GO- is asserted may cause a stop sequence followed by a track position sequence and a start sequence if GO- is still asserted. Changing the state of REV- always causes a stop sequence followed by a start sequence in the opposite direction if GO- is left active. Removal of the tape cartridge causes a stop sequence to occur.

4.2 Tape position code signals (UTH-, LTH-) are defined as follows (see Figure 3):

UTH-	LTH-	DESCRIPTION
1	1	Beginning of Tape (BOT) position.
0	1	End of Tape (EOT) position.
1	0	Warning Zone
0	0	Recording Zone (between load point hole and early warning hole providing that a beginning of tape position or end of tape position has occurred since the last cartridge insertion (CIN-), otherwise this code means "tape position unknown").

When a cartridge insertion or a reset occurs, the position of the tape within the cartridge is unknown. It shall be the responsibility of the controller to position the tape to a known position. The controller can cause the tape to move to the beginning of tape by asserting REV- and GO-. When the BOT holes are seen by the drive, UTH- and LTH- are both asserted (beginning of tape position code), and a tape stop sequence occurs. If GO- is de-asserted or if GO- and REV- are both asserted, the tape is moved forward until the BOT holes are seen, and then immediately stopped. If GO- is asserted and REV- is deasserted, the drive asserts the Warning Zone indication prior to beginning a tape start sequence. When the Load Point hole is seen by the drive, Recording Zone is asserted.

As forward motion continues, the Early Warning hole crosses the sensors and Warning Zone is asserted. When the EOT hole is seen by the drive, End of Tape position code is asserted, and a tape stop sequence occurs. If GO- is asserted and REV- is deasserted, or if GO- is deasserted, the tape is moved in reverse until the EOT hole is again seen and then immediately stopped. End of Tape position code will continue to be asserted. When REV- and GO- are asserted, the drive asserts the Warning Zone indication prior to beginning the tape start sequence. Further events in the reverse direction are analogous to the description of forward events.

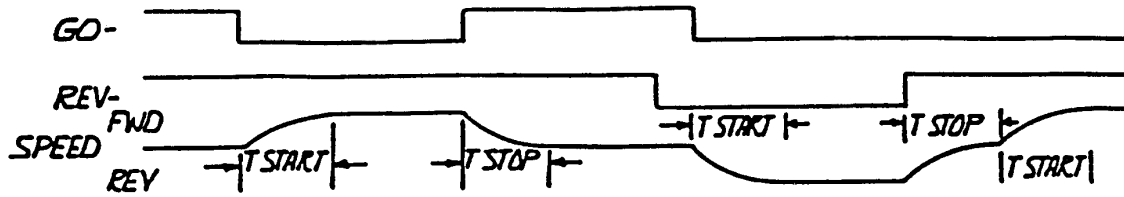

*T START*      *300 MSEC MAX*  
*T STOP*        *300 MSEC MAX*

MOTION CONTROL TIMING

Figure 2

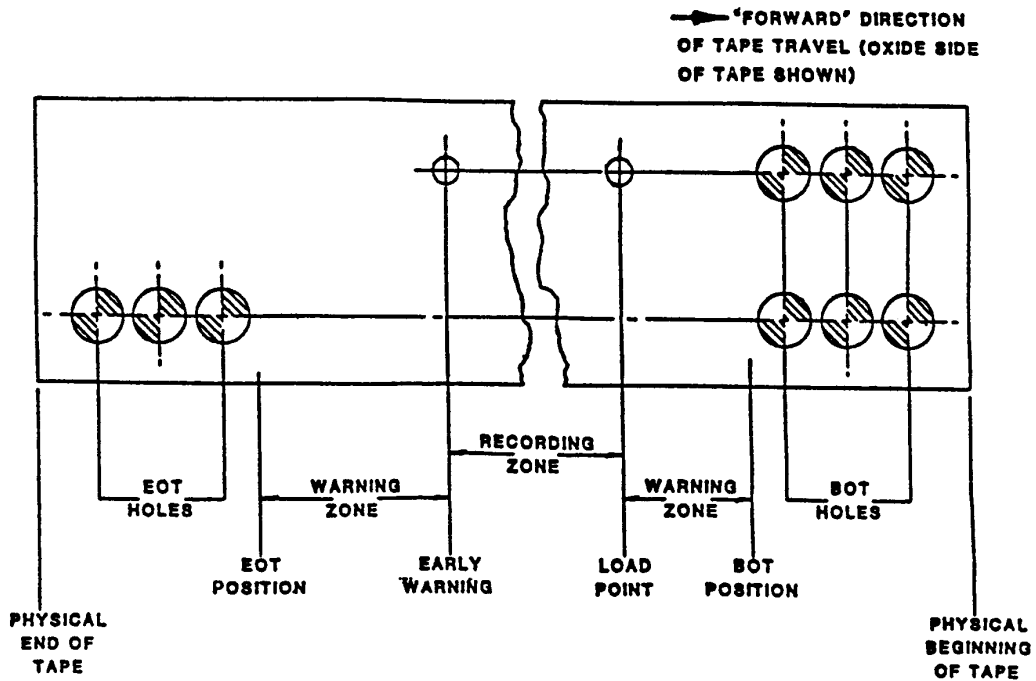

Latched Tape Hole and Tape Position Hole Relationships

Figure 3

## 5.0 WRITE AND ERASE CHANNELS

When enabled (DS0- and WEN- asserted), the write drivers supply current to the selected write head. Positive or negative current through the selected head is controlled by the complementary Write signals WDA+ and WDA-.

Head selection is controlled by the track select bits. Write current appropriate for operation with high coercivity cartridge tape is enabled if HC- (high current) is true; otherwise, write current appropriate for operation with cartridge tape which complies with ANSI X3.55-1982 is enabled.

The Write Driver is disconnected when the File Protect Plug on the tape cartridge is in the SAFE position, and during power up and down of the +5 VDC. The drive shall ensure full protection of written tapes during power up and down. The Erase Driver is enabled when the Drive is selected, EEN- is asserted and track 0 is selected. The AC erase signal is internally generated by the drive.

As the Write and Read channels are designed for high density digital recording, low density recording is not allowed. With writing enabled, data transitions must occur only at intervals of 1.11, 2.22 or 3.33  $\mu\text{sec} \pm 1\%$  for 90-ips drives and three times that for 30-ips drives. The recording code must comply with these requirements.

## 6.0 READ CHANNEL

Selection of the Read Head is controlled by the track select bits. The signal from the selected Read Head is converted to a TTL logic level. A single read pulse (RDP-) is generated for each transition as shown in Figure 4. When THD- is true, a percentage of nominal signal amplitude threshold is invoked to eliminate marginal recording areas from the magnetic media. This is normally used during a Read-after-Write operation.

The controller design should tolerate bit shifts (deviations of read level transitions) of up to 37% of the nominal minimum bit cell time.

Read channels are not designed to read data from a track in the direction opposite from which it was recorded.

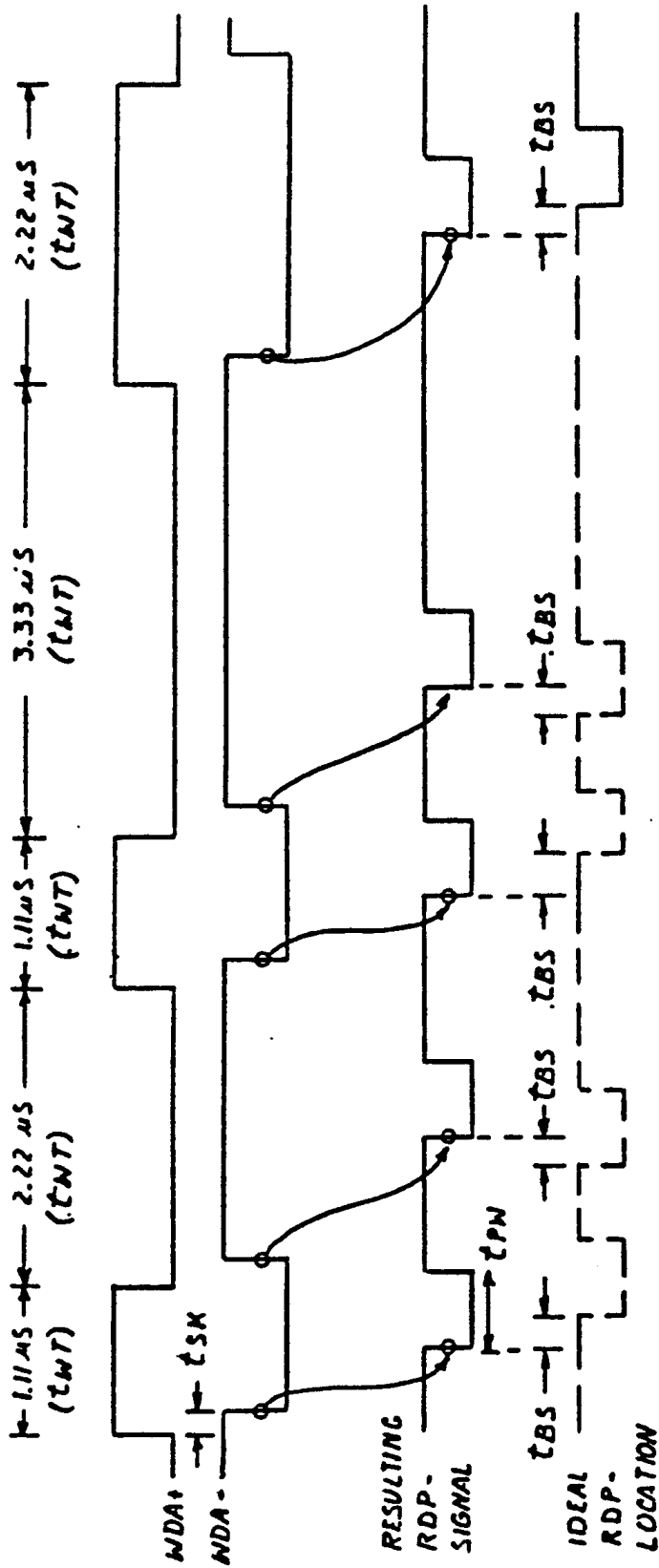

READ/WRITE SIGNAL TIMING

FIG. 4.

- tSK = WDA+ / WDA- SKEW - 15 ns ± tSK ± ± 15 ns
- tPN = RDP- PULSE WIDTH 200 ± tPN ± 650 ns
- tCBS = RDP BIT SHIFT FROM IDEAL RDP LOCATION - 0.91 μs ± tCBS ± ± 0.91 μs
- tWNT = WRITE DATA TRANSITION INTERVAL (WITHOUT PRECOMPENSATION) tWNT = 1.11 μs ± 1%  
2.22 μs ± 1%  
3.33 μs ± 1%